

## C. ELECTRICAL INSTALLATION REQUIREMENTS

### **WIRE SIZE IS CRITICAL / LOW VOLTAGE CONDITION – Failure to follow these guidelines will damage the HydraStar™ unit and void your warranty.**

It is critical that the BLACK power lead and WHITE ground lead from the tow vehicle to the input of the HydraStar™ actuator are sized and terminated. (i.e. dedicated 25-40\* amp circuit on the tow vehicle – 12 gauge wire minimum). 10 gauge wire is recommended to optimize performance. Consult the SAE wiring guidelines for proper trailer electrical harness design.

It is critical that the solid blue wire from the in-cab electronic brake control is connected to the solid blue wire on the HydraStar™ actuator. It is also critical that the yellow or blue w/ white striped wire from the HydraStar™ actuator is connected to the cold side of the trailer emergency breakaway switch. Under no circumstances should the solid blue wire and the yellow or blue w/ white stripe wire be connected together.

\* = Cold temperature (below 0° F) applications require 40 amp.

**REQUIRES AN IN-CAB ELECTRONIC CONTROL** – The HydraStar™ actuator is intended to be used with an in-cab electronic brake controller. The unit will operate with a wide variety of controllers but provides optimum performance when used with a CARLISLE® electronic brake controller. Contact your dealer for a list of approved brake controllers. The list is also available online at [www.carlislebrake.com](http://www.carlislebrake.com). The in-cab controller must have an output capacity of at least 5 amps for proper operation of the HydraStar™ actuator.

**ELECTRICAL CONNECTIONS** – Make sure all electrical connections are clean, dry, weather tight, and secure to prevent damage to the wiring from dragging or becoming entangled with foreign objects. CARLISLE® highly recommends soldering all electrical connections. A dedicated ground connection between the tow vehicle and trailer is also required.

**BREAKAWAY BATTERY REQUIREMENT** - To comply with federal requirements, the trailer must be equipped with a breakaway switch and battery. The breakaway battery needs to have a minimum capacity of 5 amp hours and needs to be maintained in a fully charged condition at all times. The breakaway battery should be checked for proper charge level before every use.

**CHARGING THE BREAKAWAY BATTERY** – A separate battery charger is included in the Carlisle® breakaway battery kit that draws power from the keyed accessory terminal on the tow vehicle. Attempting to charge the breakaway battery directly from the keyed accessory terminal without the appropriate charger will over heat and damage the trailer breakaway battery.

# ELECTRICAL SCHEMATIC

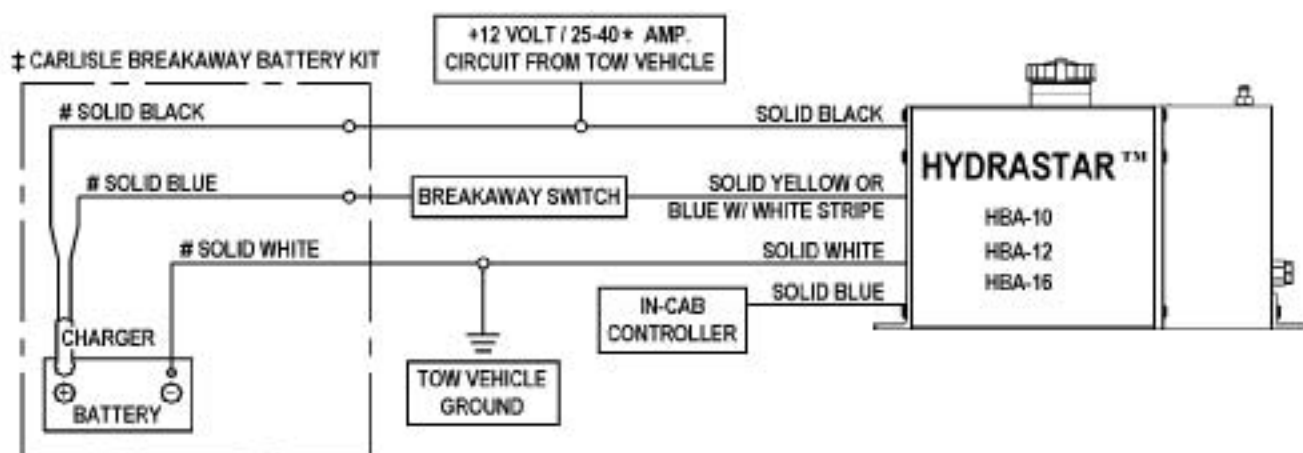

\* = COLD TEMPERATURE ( BELOW 0° F ) APPLICATIONS REQUIRE 40 AMP.

‡ = THIS ELECTRICAL SCHEMATIC REPRESENTS THE USE OF A CARLISLE BREAKAWAY BATTERY KIT. PLEASE NOTE THAT IF YOU ARE USING A DIFFERENT BREAKAWAY BATTERY KIT, THERE MAY BE A DIFFERENT NUMBER OF WIRES AND THE CHARGING +12VOLT, BREAKAWAY, AND GROUND CIRCUITS MAY BE IDENTIFIED BY COLORS OTHER THAN THOSE DEPICTED IN THIS SCHEMATIC. PLEASE CONSULT THE MANUFACTURER'S INSTRUCTIONS TO IDENTIFY THE AFOREMENTIONED CIRCUITS.

# = CIRCUITS FOR THE CARLISLE BREAKAWAY BATTERY KITS WILL BE IDENTIFIED AS FOLLOWS:

CHARGING +12 VOLT CIRCUIT - BLACK  
 BREAKAWAY CIRCUIT - BLUE  
 GROUND CIRCUIT - WHITE

Note – The HydraStar™ actuator does not draw power from the tow vehicle accessory lead unless the brakes on the tow vehicle are actuated.

## IMPORTANT – CONSULT YOUR VEHICLE OWNER'S MANUAL

Be sure to read your vehicle owner's manual to see what it says about vehicle to trailer wiring. More and more vehicle manufacturers are recommending special precautions be taken to protect the more sophisticated electronics on the newer vehicles.